

Compressed Air Cooling Air AHP/AHPH Series

BRAZED ALUMINUM CONSTRUCTION

Features

- Full Line of Sizes and Features
- Brazed Bar and Plate Aluminum Core
- Energy Efficient
- High Performance
- High Flows 400-3500 CFM
- Vertical (AHP) or Horizontal (AHPH) Air Flow
- High Technology Compact Design
- Optional Air Motor
- Rugged Heavy Duty Construction
- Excellent for Heat Recovery
- Detachable Legs on AHP (shipped unattached) Fixed Mounting Feet on AHPH
- CRN Available*



Ratings

Maximum Operating Pressure 250 psi
Maximum Operating Temperature 350°F
***CRN Rating** 235 psi at 250°F (121°C)

Materials

Cabinet Steel with Baked Enamel Finish
Core Brazed Aluminum Bar and Plate
Fan Aluminum Hub, Polypropylene Blades
Shroud Painted Steel
Motor TEFC
Fan Guard Steel with Baked Enamel Finish

How to Order

AHP	-		-	
Model Series AHP		Model Size Selected 400 725 950 1200 1600 2000 2500 3000 3500		Specify Motor Required 0 - No Motor 2 - Single Phase 60 Hz TEFC 115/208-230 Volt 3 - Three Phase 60 Hz TEFC 230/460 Volt 5 - Air Motor 6 - 575 Volt

AHPH	-		-	
Model Series AHPH		Model Size Selected 400 725 950 1200 1600 2000		Specify Motor Required 0 - No Motor 2 - Single Phase 60 Hz TEFC 115/208-230 Volt 3 - Three Phase 60 Hz TEFC 230/460 Volt 5 - Air Motor 6 - 575 Volt

Dimensions

AHP – Vertical Air Flow

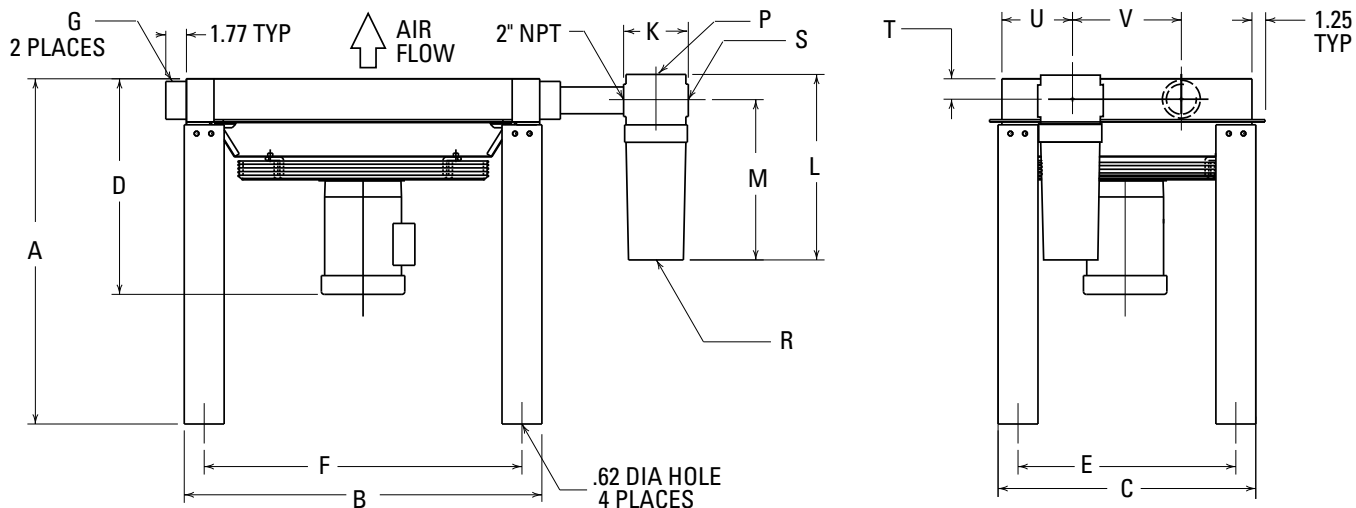

Model	A	B	C	D (Approx.)		E	F	G NPT	Optional Separator					T	U	V	Recommended Optional Separator Model Number	
				Electric Motor	Air Motor				K	L	M	P NPT	R NPT					S NPT
AHP-400	34.20	22.6	17.96	18.01	13.55	13.96	18.68	2.00	4.70	18.60	16.00	N/A	.50	2.00	1.85	6.00	4.92	S-600M
AHP-725	34.20	30.56	22.37	18.01	13.55	18.37	26.56	2.00	4.70	18.60	16.00	N/A	.50	2.00	1.85	6.00	9.34	S-600M
AHP-950	36.01	37.24	26.78	22.76	19.01	22.78	33.24	3.00	8.00	23.00	20.00	N/A	.50	2.00	1.85	6.00	13.76	S-1700M
AHP-1200	36.01	41.19	26.78	25.07	20.50	22.78	37.19	3.00	8.00	23.00	20.00	N/A	.25	3.00	2.76	6.00	13.76	S-1700M
AHP-1600	36.01	41.19	34.89	25.95	17.06	30.89	37.19	3.00	8.00	23.00	20.00	.50	.25	3.00	2.76	8.00	17.86	S-2600M
AHP-2000	36.01	51.04	37.88	27.57	22.23	33.88	47.04	4.09	16.75	30.50	23.25	.50	.25	3.00	2.76	8.00	20.86	S-2600M
AHP-2500	36.01	49.07	43.70	28.01	22.23	39.70	45.07	4.09	16.75	30.50	23.25	.50	.75	4.00	2.76	8.00	26.68	S-2600M
AHP-3000	36.01	51.04	52.52	29.17	23.56	48.52	47.04	4.09	16.75	30.50	23.25	.50	.75	4.00	2.76	8.00	35.50	S-2600M
AHP-3500	36.01	51.04	56.30	29.17	23.56	52.30	47.04	4.09	16.75	30.50	23.25	.50	.75	4.00	2.76	8.00	39.28	S-2600M

Note: We reserve the right to make reasonable design changes without notice. All Dimensions are in inches.



Dimensions

AHPH – Horizontal Air Flow

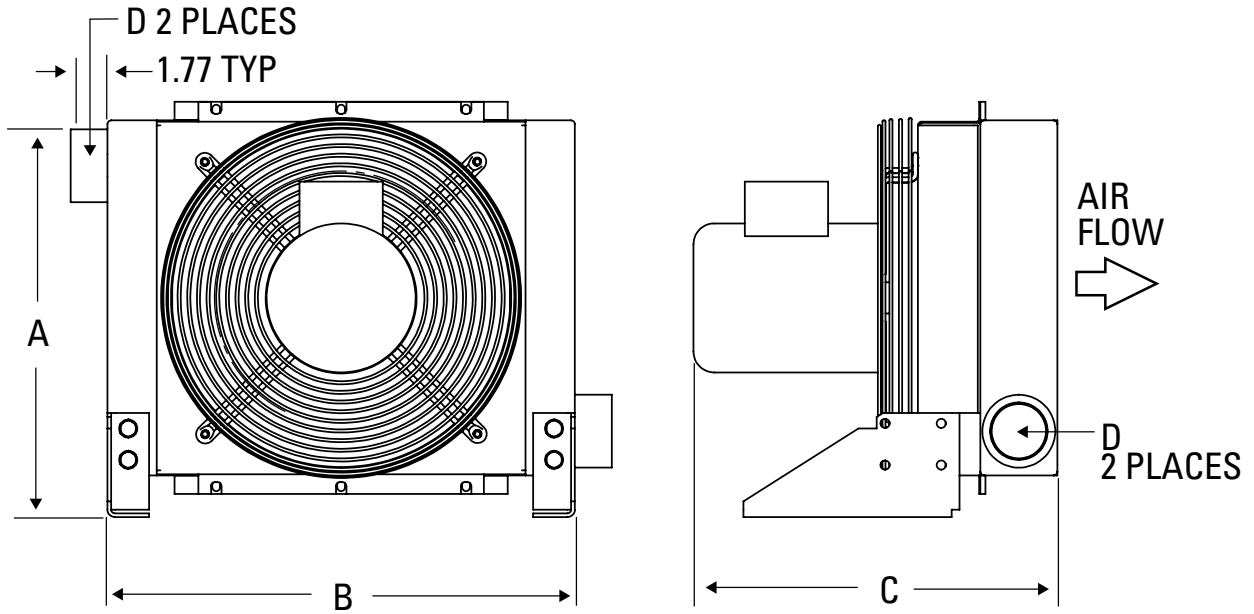

Model	A	B	C		D NPT	Recommended Optional Separator Model Number
			Electric Motor	Air Motor		
AHPH-400	17.96	22.60	18.01	13.55	2.00	S-600 M
AHPH-725	22.37	30.56	18.01	13.55	2.00	S-600 M
AHPH-950	26.78	37.24	22.76	19.01	3.00	S-1700 M
AHPH-1200	26.78	41.19	25.07	20.50	3.00	S-1700 M
AHPH-1600	34.89	41.19	25.95	17.06	3.00	S-2600 M
AHPH-2000	37.88	51.04	27.57	22.23	4.00	S-2600 M

Note: We reserve the right to make reasonable design changes without notice. All Dimensions are in inches.

Capacity Selection Chart Max. SCFM @ 5, 10, 15 and 20°F Approach

Inlet Temp. °F	150				200				250				300				350				Recommended Optional Separator Model Number	
	Approach Temp. °F	5	10	15	20	5	10	15	20	5	10	15	20	5	10	15	20	5	10	15		20
Model	AHP(H)-400	210	384	520	605	175	375	430	500	160	300	400	464	135	250	340	396	125	235	305	355	S-600M
	AHP(H)-725	355	650	890	1025	308	560	760	880	290	545	725	840	245	450	605	701	225	410	540	625	
	AHP(H)-950	480	871	1178	1360	415	754	1020	1180	390	712	950	1100	320	588	785	910	280	520	690	780	
	AHP(H)-1200	600	1090	1475	1710	520	950	1290	1460	490	900	1200	1380	405	735	980	1130	355	650	865	990	S-1700M
	AHP(H)-1600	790	1440	1950	2260	710	1290	1720	1950	660	1200	1600	1860	530	965	1290	1480	460	840	1135	1300	
	AHP(H)-2000	980	1790	2420	2800	870	1580	2140	2460	820	1490	2000	2300	660	1210	1595	1840	572	1040	1400	1610	
	AHP-2500	1220	2220	3000	3470	1090	1980	2680	3100	1035	1880	2500	2870	784	1426	1980	2270	705	1290	1725	1980	S-2600M
	AHP-3000	1450	2650	3580	4120	1295	2360	3200	3710	1243	2260	3000	3450	985	1794	2360	2715	840	1530	2040	2350	
	AHP-3500	1680	3064	4140	4800	1530	2785	3760	4320	1460	2660	3500	4015	1150	2090	2760	3200	950	1740	2350	2700	

Above specifications are based on 80 to 125 PSIG operating pressures. Maximum pressure drop, less than 3 psi. A flexible metal hose must be properly installed between the compressor and aftercooler to validate warranty. In addition, for mobile and other applications where there may be additional stresses to the connections, our 4-bolt SAE Flange should be used. Consult factory for pricing and availability.

Electric Motor & Fan Data

Model	Fan CFM	Motor H.P.	Voltage	Phase	Full Load Amps	Hz	RPM	Nema Frame	Thermal Overload	Approx. Shipping Weight (Lbs.)	Sound dB(A) at 3 ft
AHP(H)-400	2200 1825/2200	1.0	115/208-230 208-230/460	1 3	6.0 3.6/3.2	60 50/60	3450 2850/3450	56C	No	120	97
AHP(H)-725	3600 3025/3600	1.5	115/208-230 208-230/460	1 3	8.5 4.9-4.6/2.3	60 50/60	3450 2850/3450			170	100
AHP(H)-950	4700	1.5	115/208-230 208-230/460	1 3	8.6 4.6	60*	1740	145TC		330	92
AHP(H)-1200	7000	5.0	230	1	23.0			184TC		450	94
		3.0	208-230/460	3	8.8			182TC			
AHP(H)-1600	9700	5.0	208-230/460	3	13.4	60*	1740	184TC		515	96
AHP(H)-2000	11000	7.5	230/460		19.6			213TC		600	98
AHP-2500	14000				24.8			215TC		625	98
AHP-3000	17500	10.0						645		102	
AHP-3500	17500										750

All motors shown are TEFC. Other motor options available upon request. Published electrical ratings are approximate, and may vary because of motor brand. Actual ratings are on motor nameplate.

Fan motors **must not** be cycled. Outdoor applications must be protected from direct weather. If ductwork or additional static resistance is added to the cooler airstream, an auxiliary air mover may be required.

*3 phase motors available in 50Hz. Reduce performance by 10%.

Recommended Typical Installation

- Support piping as needed. Flexible connectors must be properly installed to validate warranty.
- Coolers should not operate in ambient temperatures below 35°F (1°C). Consult factory for recommendations.
- The fan cannot be cycled.
- AHP coolers operated outdoors must be protected from weather. Consult factory for recommendations.
- If ductwork or additional static resistance is added to the cooler airstream, an auxiliary air mover may be required.

Air Motor Data

Model	PSI ¹	CFM ²	Approx. Shipping Wt. (lbs)
AHP(H)-400	60	50	105
AHP(H)-725	85	65	140
AHP(H)-950	60	55	425
AHP(H)-1200	70	100	481
AHP(H)-1600	100	180	595
AHP(H)-2000	90	230	700
AHP-2500	90	230	735
AHP-3000	100	275	795
AHP-3500	100	275	825

Note: We reserve the right to make reasonable design changes without notice. All dimensions are in inches.

¹ Air inlet to the air motor must be regulated to this pressure.

² CFM (Free Air) consumption of the air motor. Lubrication = One drop of oil for every 50-75 CFM of air going through the motor. Use detergent SAE #10 oil. Filter, regulator and lubricators for the air motors are required, but not included.